

US Army Corps
of Engineers®
New York District

Jamaica Bay Structural Alternatives

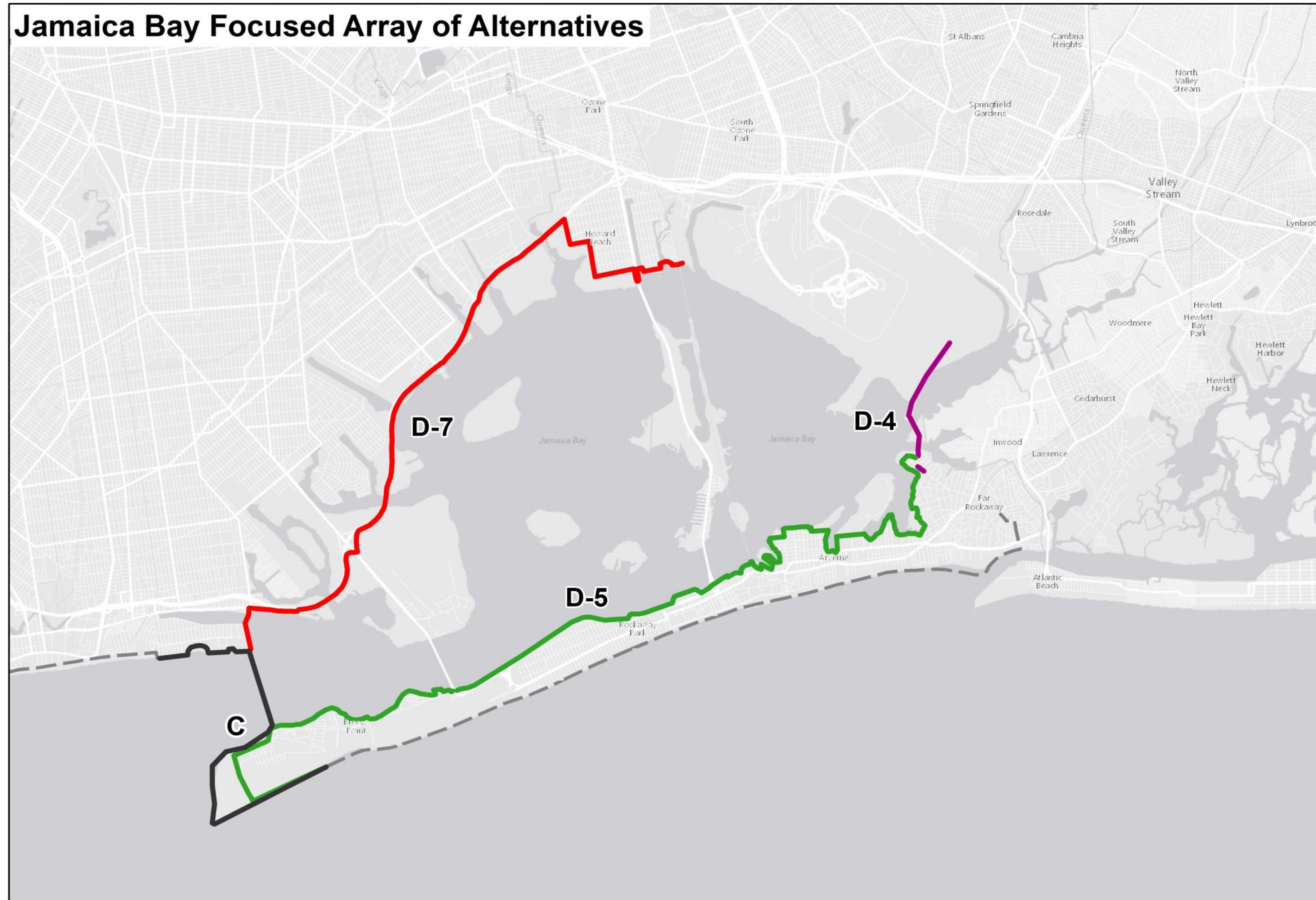

— C (Inlet Barrier) — D-7 (Jamaica Bay Northwest) — Project tie-ins
 — D-4 (Head of Bay) — D-5 (Rockaway)



C- Inlet Barrier

- Operated under storm conditions
- Provides risk reduction to entire project area
- Cannot be constructed in smaller increments
- Requires tie-in to high ground protection

D- Perimeter Plan

- Includes walls, smaller gates and nature based features constructed around the perimeter of Jamaica Bay
- Each section would reduce risks to specific communities within Jamaica Bay once completed
- Each Reach is subject to individual cost/benefit analysis
- Requires tie-in to high ground protection

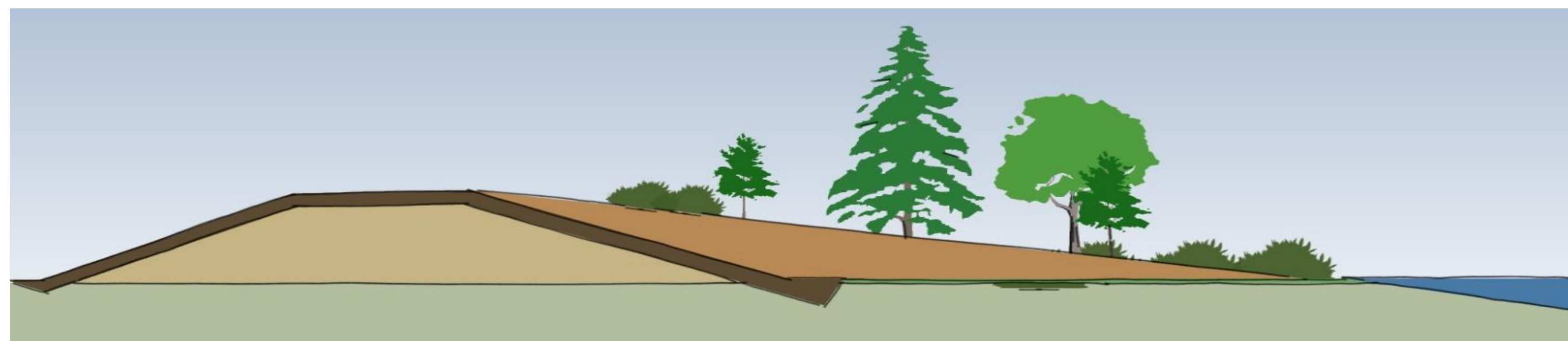

Living shoreline

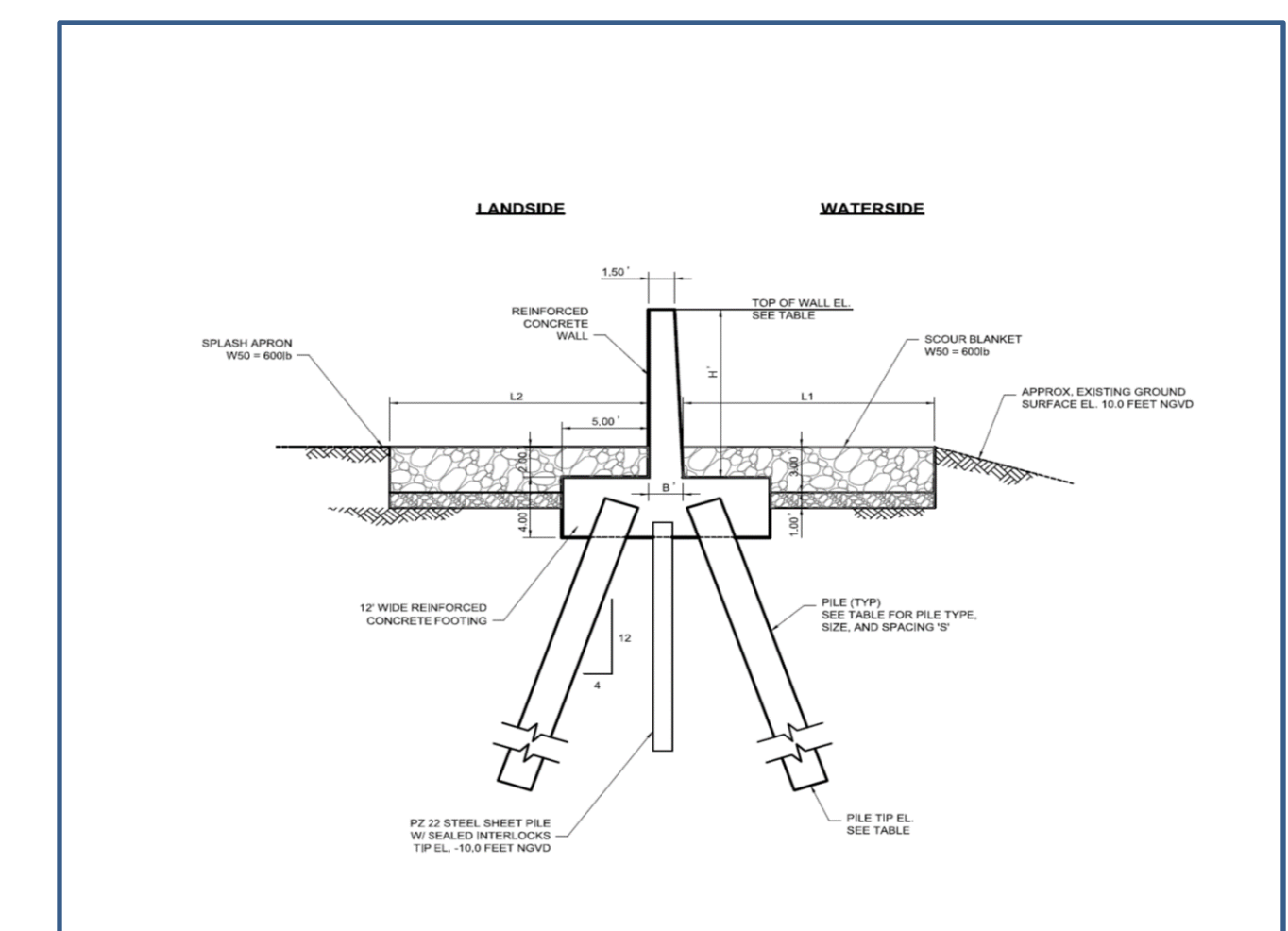

Typical wall section (T-Wall)